



# 726

# 724

# 720

Fräser mit  
Spiralverzahnung

Anwendungen/Vorteile:

- Standardfräser für Innen- und Außenkonturen
- alle Basismaterialien aus Glasgewebe
- sehr guter Spantransport und sehr gute Oberflächenqualität

Router with  
spiral-patterned teeth

Applications/Advantages:

- standard router for inner and outer contours
- all kind of glass-epoxy based materials
- excellent chip transport and surface finish

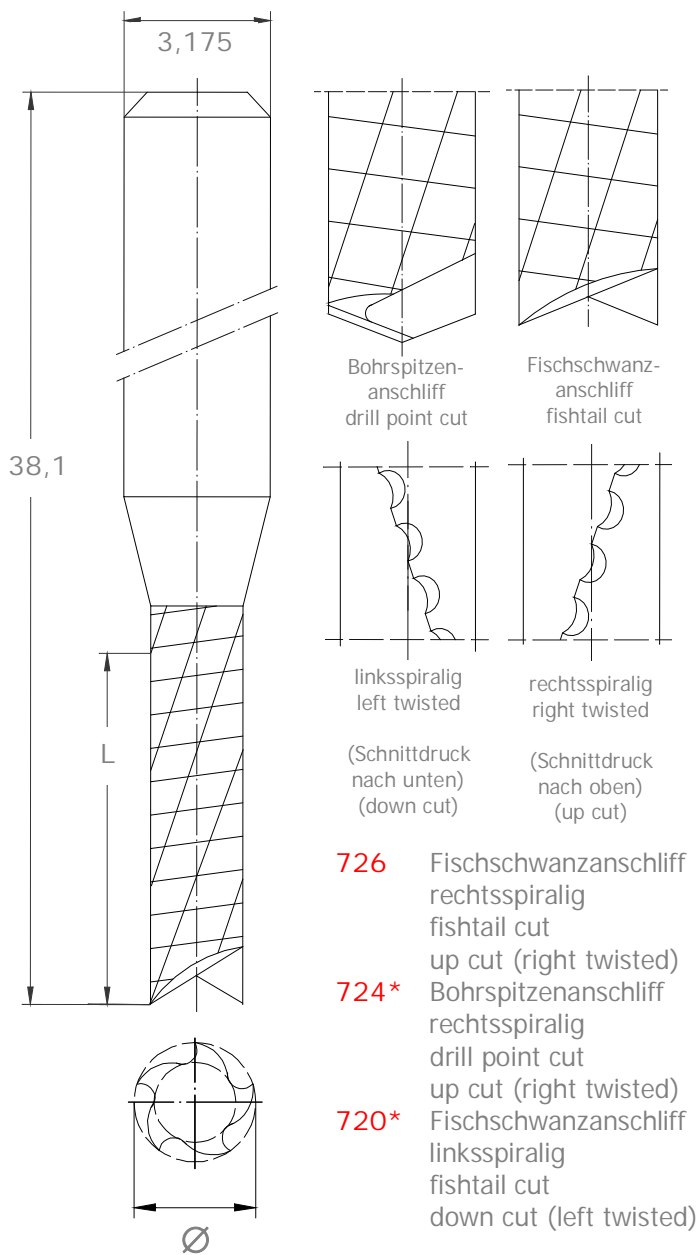

- 726** Fischschwanzanschliff rechtsspiralig fishtail cut up cut (right twisted)
- 724\*** Bohrspitzenanschliff rechtsspiralig drill point cut up cut (right twisted)
- 720\*** Fischschwanzanschliff linksspiralig fishtail cut down cut (left twisted)

726						
Ø [mm]	L [mm]					
	3,0	3,5	5,0	7,0	8,5	9,0
0,5	x					
0,6	x					
0,7		x				
0,8			x			
0,9			x			
1,0				x	x*	
1,1				x	x*	
1,2				x	x*	
1,3				x	x*	
1,4				x	x*	
1,5					x	
1,6					x	
1,7					x	
1,8					x	
1,9					x	
2,0						x
2,1						x*
2,2						x*
2,3						x*
2,4						x
2,5						x
3,0						x
3,175						x

\* auf Anfrage \* on request

HPTec GmbH  
Im Karrer 6  
D-88214 Ravensburg  
Germany

Tel.: +49 (0)751-7669-0  
Fax: +49 (0)751-7669-139  
E-Mail: sales@hptec.de  
www.hptec.de

# HPTEC