

818

Fräser mit einer Hauptschneide
Anwendungen/Vorteile:

- für Tiefenfräsen, Innenkonturen, Schlitze
- weiche Kunststoffe, Folien
- Al, Cu, Messing, Metalle
- beste Oberflächen- und Kantenqualität

1-Flute router

Application/Advantages:

- for depth routing, inner contours, slots
- soft plastics, foils
- Al, Cu, brass, metals
- best surface and edge quality

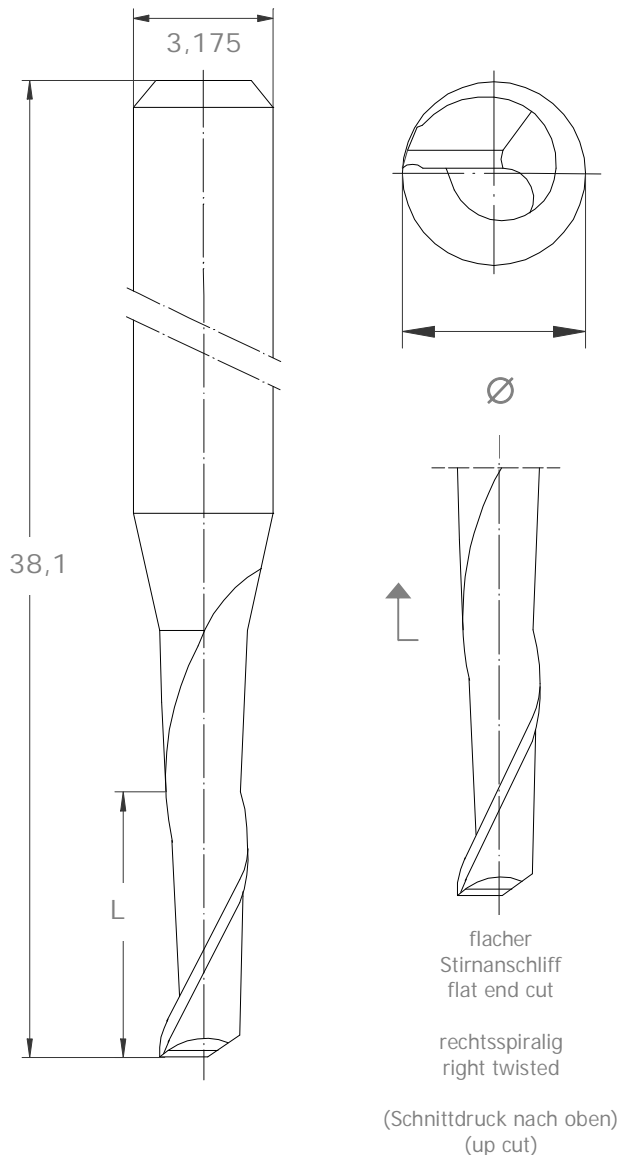

818 flacher Stirnanschliff
rechtsspiralig (Schnittdruck nach oben)
flat end cut
up cut (right twisted)

818						
Ø [mm]	L [mm]					
	1,5	3,0	4,0	5,0	8,0	9,0
0,4	x					
0,5		x				
0,6		x				
0,7		x				
0,8		x				
0,9		x				
1,0		x				
1,1		x*				
1,2			x			
1,3			x*			
1,4			x			
1,5			x			
1,6				x		
1,7				x*		
1,8				x*		
1,9				x*		
2,0					x	
2,4					x	
3,0						x
3,175						x*

* auf Anfrage * on request

HPTec GmbH
Im Karrer 6
D-88214 Ravensburg
Germany

Tel.: +49 (0)751-7669-0
Fax: +49 (0)751-7669-139
E-Mail: sales@hptec.de
www.hptec.de

HPTEC